

TECHNICAL DATA | 45° TRANSITION ELBOW MALE

Standards: AS/NZS 4129 | MS58

Size Range: 32mm x 1" - 63mm x 2"

Materials:

- Polyethylene (PE) 100
- Coated CW617N Brass

Pressure Rating: PN16, Water | PN10, Gas

Fitting Details: Male BSP Thread

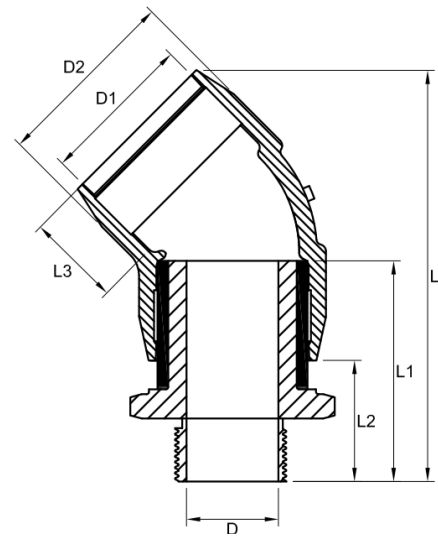

D1 mm	D inch	L mm	L1 mm	L2 mm	L3 mm	D2 mm	Fusion Time Secs	Cooling Time mins	Weight kg	Code
32	1"	160	100	61	39	44	45	5	0.26	EFTEM45321
50	1 1/2"	203.5	124	79.5	44.5	64	90	5	0.54	EFTEM4550112
63	2"	228	141	91	50	78.5	35	5	0.78	EFTEM45632

Note:

Installation should always be performed by a licensed operator. It is the responsibility of the installer to check that both the pipe(s) and fitting(s) that are installed are compatible, only compatible materials should be joined together. It is the responsibility of the licensed installer to check the PN and SDR ratings marked on the fitting(s) and ensure that the pipe is compatible. Correct installation procedures should always be followed.

The drawings, materials and specifications outlined are subject to change without notice due to the continuous improvements and development of our product range.

FUSION QLD PTY LTD

ABN: 42 987 067 369
13 Vision Court, Noosaville, QLD, 4566
42-44 South Link, Dandenong, VIC, 3175

CONTACT

T: +61 7 5474 3000 (Qld)
T: +61 3 9037 4755 (Vic)
E: sales@fusionqld.com.au
W: fusionqld.com.au