

## TECHNICAL DATA | uPVC SWING CHECK VALVE

- Standards: Compatible with AS/NZS 1477 Pressure Pipe Applications
- Size Range: 15mm - 100mm
- Materials: uPVC Body  
EDPM Flapper
- Fitting Details: Solvent Weld
- PSI: 125 Static Pressure at 22°C

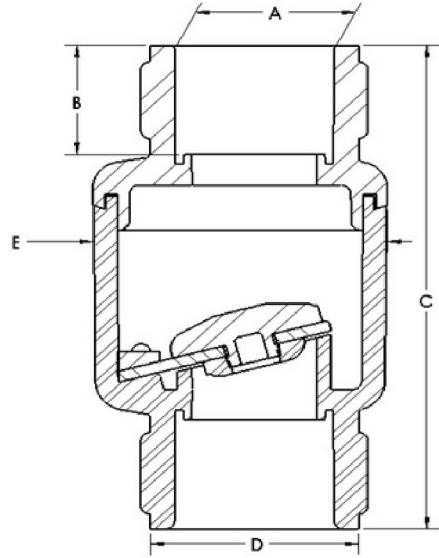

Size mm	A mm	B mm	C mm	D mm	E mm	PN Rating	Code
15	21.54	20.00	90.17	28.45	49.53	PN9	TSWCVS15
20	26.85	20.00	90.17	35.05	49.53	PN9	TSWCVS20
25	33.53	25.25	113.54	41.91	59.69	PN9	TSWCVS25
32	42.42	31.25	137.92	51.31	80.264	PN9	TSWCVS32
40	48.51	32.50	140.72	57.91	80.264	PN9	TSWCVS40
50	60.63	36.25	159.00	70.10	107.95	PN9	TSWCVS50
80	89.31	49.25	218.95	103.20	146.304	PN9	TSWCVS80
100	114.07	50.00	243.84	127.00	161.8742	PN9	TSWCVS100

**Note:**

Installation should always be performed by a licensed operator. It is the responsibility of the installer to check that both the pipe(s) and fitting(s) that are installed are compatible, only compatible materials should be joined together. It is the responsibility of the licensed installer to check the PN and PSI ratings marked on the fitting(s) and ensure that the pipe is compatible. Correct installation procedures should always be followed.

The drawings, materials and specifications outlined are subject to change without notice due to the continuous improvements and development of our product range.

**FUSION QLD PTY LTD**

ABN: 42 987 067 369  
13 Vision Court, Noosaville, QLD, 4566  
42-44 South Link, Dandenong, VIC, 3175

**CONTACT**

T: +61 7 5474 3000 (Qld)  
T: +61 3 9037 4755 (Vic)  
E: sales@fusionqld.com.au  
W: fusionqld.com.au

## TECHNICAL DATA | uPVC SWING CHECK VALVE

- Standards: Compatible with AS/NZS 1477 Pressure Pipe Applications  
 Size Range: 150mm  
 Materials: uPVC  
 Fitting Details: Solvent Weld  
 Pressure Rating: PN6

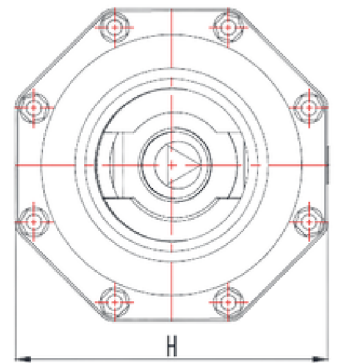
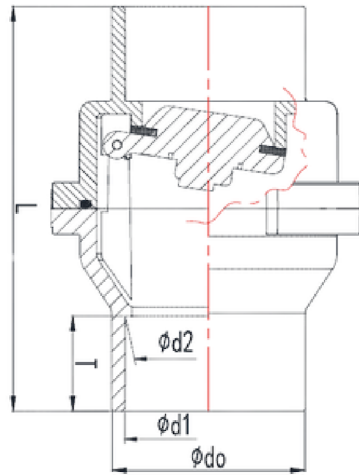

Size mm	d0 mm	d1 mm	d2 mm	T mm	L mm	H mm	Code
150	186	160.8	159.9	87	390	285	TSCVS150

**Note:**

Installation should always be performed by a licensed operator. It is the responsibility of the installer to check that both the pipe(s) and fitting(s) that are installed are compatible, only compatible materials should be joined together. It is the responsibility of the licensed installer to check the PN and PSI ratings marked on the fitting(s) and ensure that the pipe is compatible. Correct installation procedures should always be followed.

The drawings, materials and specifications outlined are subject to change without notice due to the continuous improvements and development of our product range.

**FUSION QLD PTY LTD**

ABN: 42 987 067 369  
 13 Vision Court, Noosaville, QLD, 4566  
 42-44 South Link, Dandenong, VIC, 3175

**CONTACT**

T: +61 7 5474 3000 (Qld)  
 T: +61 3 9037 4755 (Vic)  
 E: sales@fusionqld.com.au  
 W: fusionqld.com.au